



rizoma

PART NUMBER:

LC500

NAME:

Leva frizione
Clutch lever



ATTENZIONE : IL MONTAGGIO DEL PRODOTTO DEVE ESSERE ESEGUITO DA PERSONALE SPECIALIZZATO
WARNING : INSTALLATION SHOULD BE PERFORMED BY A QUALIFIED TECHNICIAN

MOUNTING INSTRUCTION - ISTRUZIONI DI MONTAGGIO
MONTAGEANLEITUNG - INSTRUCTIONS DE MONTAGE
INSTRUCCIONES DE MONTAJE

SMONTAGGIO PERNO OEM PER POMPA FRIZIONE
DISASSEMBLE OEM PIN FOR CLUTCH MASTER CYLINDER

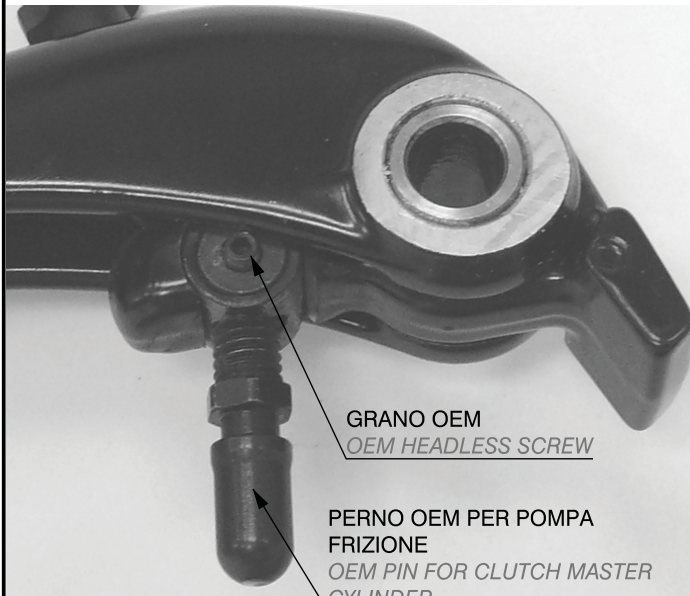

ATTENZIONE: PRIMA DI SMONTARE IL PERNO OEM PER POMPA FRIZIONE SVITARE COMPLETAMENTE IL GRANO OEM.

WARNING: BEFORE TO DISASSEMBLE THE OEM PIN FOR CLUTCH MASTER CYLINDER UNSCREW COMPLETELY THE OEM HEADLESS SCREW

MONTAGGIO LEVA FRIZIONE
ASSEMBLE CLUTCH LEVER

FIGURA 1
FIGURE 1

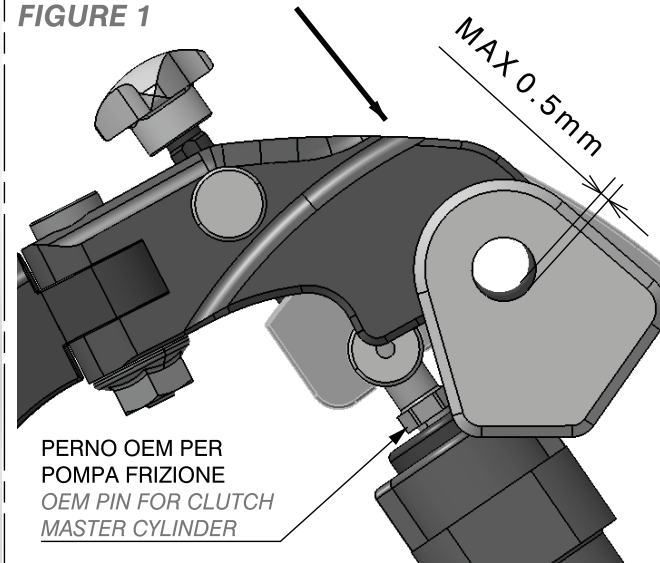

ATTENZIONE: PER UN CORRETTO MONTAGGIO APPLICARE UNA LEGGERA PRESSIONE SULLA LEVA FRIZIONE (MAX 0.5mm) PER INSERIRE LA VITE OEM (VEDI FIG.1).PER OTTENERE QUESTA REGOLAZIONE AVVITARE O SVITARE IL PERNO OEM PER POMPA FRIZIONE,IN SEGUITO SERRARE IL GRANO FORNITO(VEDI FIG.2).

WARNING: FOR THE CORRECT INSTALLATION APPLY A LIGHT PRESSURE ON THE CLUTCH LEVER (MAX 0.5 mm) TO INSERT THE OEM SCREW (SEE FIG.1).TO GET THIS ADJUSTMENT SCREW OR UNSCREW THE OEM PIN FOR CLUTCH MASTER CYLINDER,AFTER TIGHTENING THE FURNISHED HEADLESS SCREW (SEE FIG.2).

FIGURA 2
FIGURE 2

